



The Durashield LD Series seals are a cost effective solution which virtually eliminates shaft leakage and extends bearing life. Our efficient design can drastically reduce on-site maintenance costs and loss of process materials. This design is widely used throughout the Food and Pharmaceutical industry for sealing Screw Conveyors, Bucket Elevators, Mixers, Screw Feeders and Crushers in non-weight bearing applications.

Air purged operation allows for reduced internal drag, cooling and increased sealing capabilities. The LD series seals are ideal for processing bulk materials at lower temperature and speeds.

- Standard production shaft sizes: 1.50" to 3.437" (metric sizing available)
- Easy installation & Setup
- Cost Effective Solution

TECHNICAL SPECIFICATIONS:

- Temperature Capability: **-60°F to +250°F**
- Pressure Holding: 20 psig
- Vacuum Holding: 10 hg
- Air Purge Connection Operating Pressure: 5-7 psig
- Typical Air loss: 1.5 - 2.0 SCFM
- Maximum Shaft Run Out: .250" TIR
- Stuffing Box Misalignment: .015 TIR per inch of shaft
- Shaft Growth: ± 0.062"
- Shaft Tolerance: ± 0.062"
- Mounting Deviation: 1°
- Standard Housing Thickness: 1.750"
- Minimum Housing Thickness: 1.750"
- Shaft Speed: Variable by shaft diameter
- Torque setting for seal mounting: 30 Ft.lbs

STANDARD CONFIGURATION:

- Compliant for Food, Dairy, Pharmaceutical & Non-Corrosive processing
- Effective for light duty processing of mild powders or slurry materials.
- Process rated for **-60°F to 250°F**
- Housing: High-Density Polyethylene (HDPE)
- Faceplate: High-Density Polyethylene (HDPE)
- Elastomer Boot: EPDM-Silicone (FDA Compliant)
- Wear Plates: PTFE-Teflon (FDA Compliant)
- Wear Rings: 304 Stainless Steel
- Purge: Air

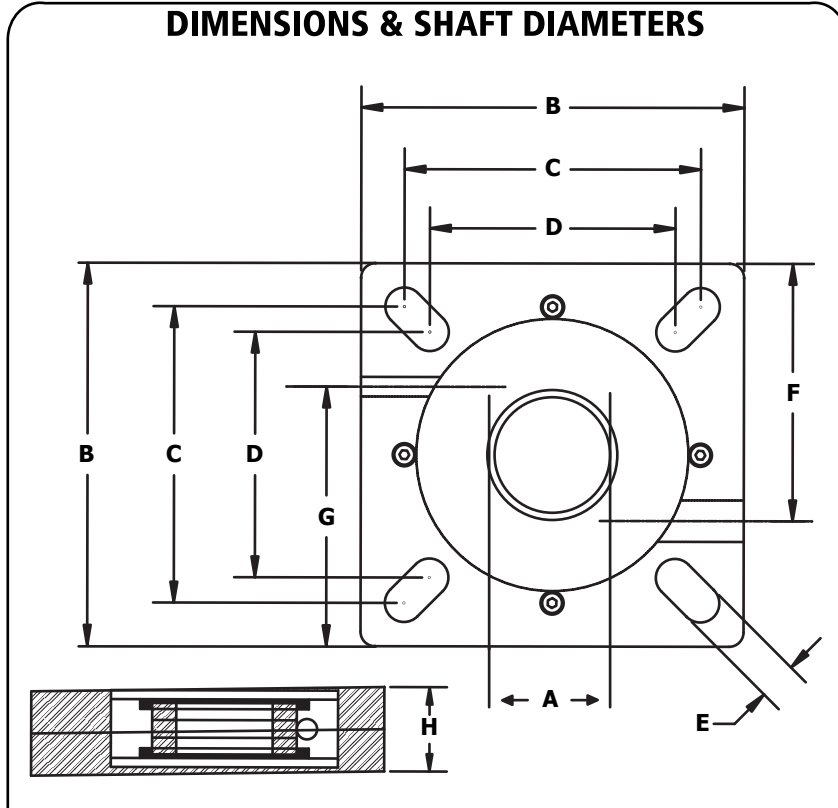

A - SHAFT DIA.	B - HOUSING	C - BOLT SQ. MAX	D - BOLT SQ. MIN	E - SLOT WIDTH	F - ELASTOMER ADJ.	G - AIR LINE	H - THICKNESS
1.50"	5.50"	4.25"	4.00"	0.66"	3.82"	3.82"	1.75"
2.00"	6.50"	5.13"	4.25"	0.66"	4.00"	4.41"	1.75"
2.44"	7.50"	5.88"	5.38"	0.68"	5.56"	4.94"	1.75"
3.00"	8.00"	6.13"	5.88"	0.80"	5.72"	5.19"	1.75"
3.44"	9.25"	7.48"	6.17"	0.80"	6.75"	5.85"	1.75"

Dimensionally configured for Type E and SCM Medium Duty 4-Bolt Flange Bearings. LD Series seals are available in standard shaft sizes from 1-1/2" to 3-7/16". LD Series seals are stock items. For additional information please visit www.agdproducts.com or call **Toll Free 1-877-243-7325**

